

COIN SLIDE

COMMERCIAL REAR CONTROL FRONT LOAD WASHER

Built for Reliable Performance

Engineered and built like no other, the Speed Queen coin slide operated front load washer is designed to be everything people thought a washer couldn't be, beginning with its revolutionary suspension and sensing technology. This groundbreaking innovation manages and redistributes out-of-balance loads to deliver uninterrupted cycles, virtually eliminate vibration and operate so quietly neighboring residents won't even know it's running. It also touts an incredible 440 G-Force extraction speed to maximize moisture removal, reduce dry times and minimize utility costs. And as if that's not game-changing enough, this smooth-running, laundry-optimizing machine delivers increased water efficiency and the ultimate user experience. It's everything you never knew it could be.

- Revolutionary balancing technology
- Industry leading 1200 RPM spin speed exerts 440 G-force extraction
- Extra-wide 15.5" door opening and 180° door swing
- Rugged suspension system
- Durable stainless steel tub
- Four-compartment soap dispenser



ENERGY STAR® Certified Washer

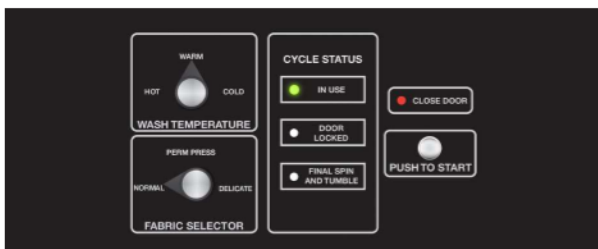

Coin Slide control offers heavy-duty operation, is easy to use and offers the basic features needed for optimal coin-vended laundry room operations.

SPECIFICATIONS

COMMERCIAL REAR CONTROL FRONT LOAD WASHER

MODEL - see below for all models and activation available	
CONTROL OPTION	Coin Slide
COLOR	White
CAPACITY - lb (kg)	21.5 (9.5)
CYLINDER VOLUME - cu. ft. (liters)	3.26 (92.3)
SPIN SPEED G-FORCE (RPM)	150 (710)
MOTOR SIZE - HP (kw)	0.9 (0.67)
WATER CONSUMPTION PER CYCLE - g (liter)	13.68 (51.8)
IWF (WATER FACTOR) - gal/ft ³ (liters/liter/cycle)	4.0 (0.53)
MEF _p (Modified Energy Factor) ft ³ /kWh/cycle (Liters/kWh/cycle)	2.20 (62.3)
CYCLE SELECTIONS	Normal Hot, Normal Warm, Normal Cold, Delicate, Perm Press Cold, Perm Press Warm
ELECTRICAL REQUIREMENTS (v/Hz/Ph-Amp)	120/60/1 - 15 Amp
WATER PRESSURE - p.s.i. (bar)	20-120 (1.4/8.3)
DRAIN	Pump
CYLINDER FINISH	Stainless Steel
NET WEIGHT - lb (kg)	260 (118)
SHIPPING WEIGHT - lb (kg)	270 (122.5)
SHIPPING DIMENSIONS APPROX. - in (mm)	Width 34 (864)
	Depth 30 (762)
	Height 44.5 (1130)
AGENCY APPROVALS	cULus

MODELS	ACTIVATION
SFNSXRSP115TW02	Coin Slide 

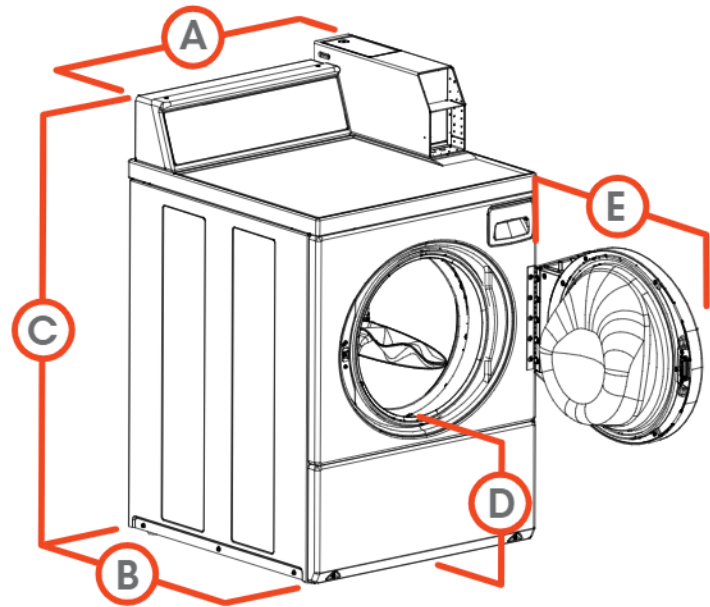

A. OVERALL WIDTH - in (mm)	26.875 (683)
B. OVERALL DEPTH - in (mm)	27.73 (704)
C. OVERALL HEIGHT - in (mm)	40.42 (1027)
D. FLOOR TO DOOR OPENING -in (mm)	14.6 (371)
E. DOOR SWING - in (mm)	24 (610)

For the most accurate information, the installation guide should be used for all design and construction purposes. Due to continuous product improvements, design and specifications subject to change without notice. The quality management system of Alliance Laundry Systems' Ripon facility has been registered to ISO 9001:2000.



by Alliance Laundry Systems

speedqueencommercial.com/multihousing

AM18-0017 • ©2018 Alliance Laundry Systems LLC